



Order code: IS2GSCXBAB

Premium gen-set controller compliant to the latest world Grid Codes requirements

Datasheet

Product description

- ▶ The Intelisys GSC-C is a powerful controller for complex applications with new grid codes standards requirements.
- ▶ Preconfigured functions, scalable and configurable I/Os and large in-built PLC interpreter allows to adapt the controller to various, demanding requirements without greater effort

Key features

- ▶ Compliant to the latest world grid codes standards:
 - European Union - **EU 631/2016 Requirements for Generators**
 - Germany - **VDE-AR-N 4110:2018, VDE-AR-N 4105:2018** (Component certification)
 - United Kingdom - **G99**
 - USA - **IEEE 1547-2018**
 - Others
- ▶ Predefined, adjustable functions for gen-set control allows easy and fast gen-set commissioning.
- ▶ Large built-in PLC interpret to suit individual needs and design demanding applications.
- ▶ Support of wide range applications – from single to multiple, from island to network parallel operation.
- ▶ Support of wide range of electrical engines, ECUs.
- ▶ Powerful power management function optimizing number of running gen-sets.

- ▶ Automatic Load and Var sharing over CAN line (requires HW dongle).
- ▶ Plug&Play support of ComAp InteliVision display family.
- ▶ Automatic synchronization and power control.
- ▶ Baseload, Imp / Exp, TempByPower, Peak shaving, Voltage and PF control (AVR bias output).
- ▶ Event-based and PreMortem history with customer selectable list of stored values; RTC; statistic values.
- ▶ Tier IV Final and Stage V engines support
- ▶ Hybrid installations support

Application overview

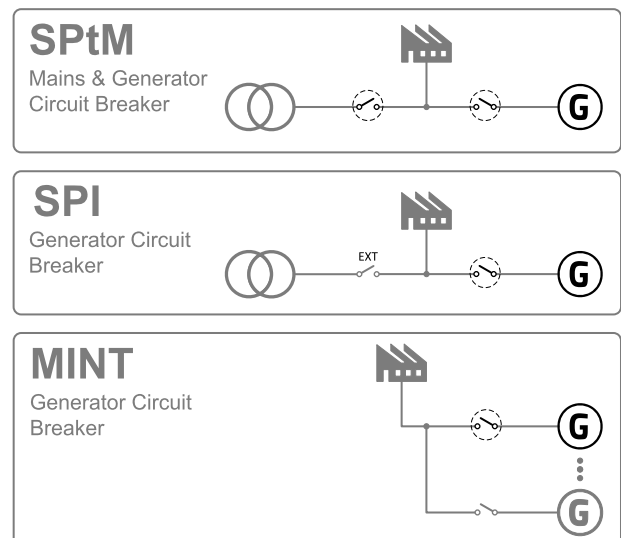

Technical data

Power supply

Power supply range	8-36 V DC
Power consumption	0.4 A / 8 V DC
	0.15 A / 24 V DC
	0.1 A / 36 V DC
RTC battery	10 years (replaceable by official service)
Fusing	2 A (without BOUT consumption)
Max. Power Dissipation	16 W

Operating conditions

Operating temperature	-40 °C to +70 °C
Storage temperature	-40 °C to +80 °C
Max. operating altitude	2000 m above sea level
	4000 m above sea level for max Ph-Ph voltage 400V AC
Operating humidity	95 % non-condensing (EN 60068-2-30)
Vibration	5-25 Hz, ±1.6 mm 25-100 Hz, a = 4 g
Shocks	a=200 m/s ²
Heat radiation	16 W

Voltage measurement

Measurement inputs	3 ph-n Gen voltage 3 ph-n Mains/Bus voltage
Measurement range	110 V / 277 V
Max allowed voltage	125 % ph-n
Accuracy	1 % of 110 V / 277 V
Frequency range	40-70 Hz (accuracy 0.1 Hz) 45-65 Hz (acc below 0.01 Hz)
Input impedance	0.6 MΩ ph-ph 0.3 MΩ ph-n

Current measurement

Measurement inputs	3 ph Gen current 1 ph Mains current
Measurement range	1 A / 5 A
Max allowed continuous current	200 % / 200 %
Accuracy	2 % of 1 A / 5 A
Input impedance	<0.1 Ω

Binary inputs

Number	16 non-isolated
Input resistance	4.7 kΩ
Close/Open indication	0-2 V DC close contact >4 V DC open contact

Binary outputs

Number	16 non-isolated
Max current	0.5 A (2 A per group)
Switching to	Negative/positive supply terminal

Analog inputs

Number	4 non-isolated
Type	Switchable (Voltage, Resistance, Current)
Resolution	10 bits, max 4 decimals
Range	0-5 V DC / 0-2500 Ω / 0-20 mA
Input impedance	>100 kΩ / >100 kΩ / 180 Ω
Accuracy	±1 % of meas. value ±5 mV
	±2 % of meas value ±2 Ω
	±1 % of meas value ±0.5 mA

Analog outputs

Number	1
Type	Switchable (Voltage, Current)
Range	0-10 V DC / 0-20 mA
Max current/load	5 mA / 500 Ω
Accuracy	±0.5 % of output value ±20 mV
	±0.5 % of output value ±100 µA

Magnetic pick-up

Voltage input range	2 Vpk-pk to 50 Veff
Frequency input range	4 Hz to 15 kHz
Frequency measurement tolerance	0.2 %

Voltage regulator output

Type	5 V TTL PWM / ±10 V DC with IG-AVRi interface
------	---

Speed governor output

Voltage output	±10 V DC / max. 10 mA
Voltage output via resistor	±10 V DC via 10 kΩ resistor / max . 1 mA
PWM	500÷3000 Hz / 5V / max. 10mA

Communications

RS232	Direct/Modbus, non-isolated
RS485	Direct/Modbus, isolated
Display port	non-isolated RS485, only terminal connection
USB port	Direct, isolated
Ethernet port	LAN/Internet, Modbus TCP, SNMP, WebServer, AirGate
CAN1	External modules 250 kbps, max 200 m, Isolated
CAN2	Intercontroller and comm extensions 250 / 50 kbps, max 200 / 1000 m, Isolated

Dimensions, terminals and mounting

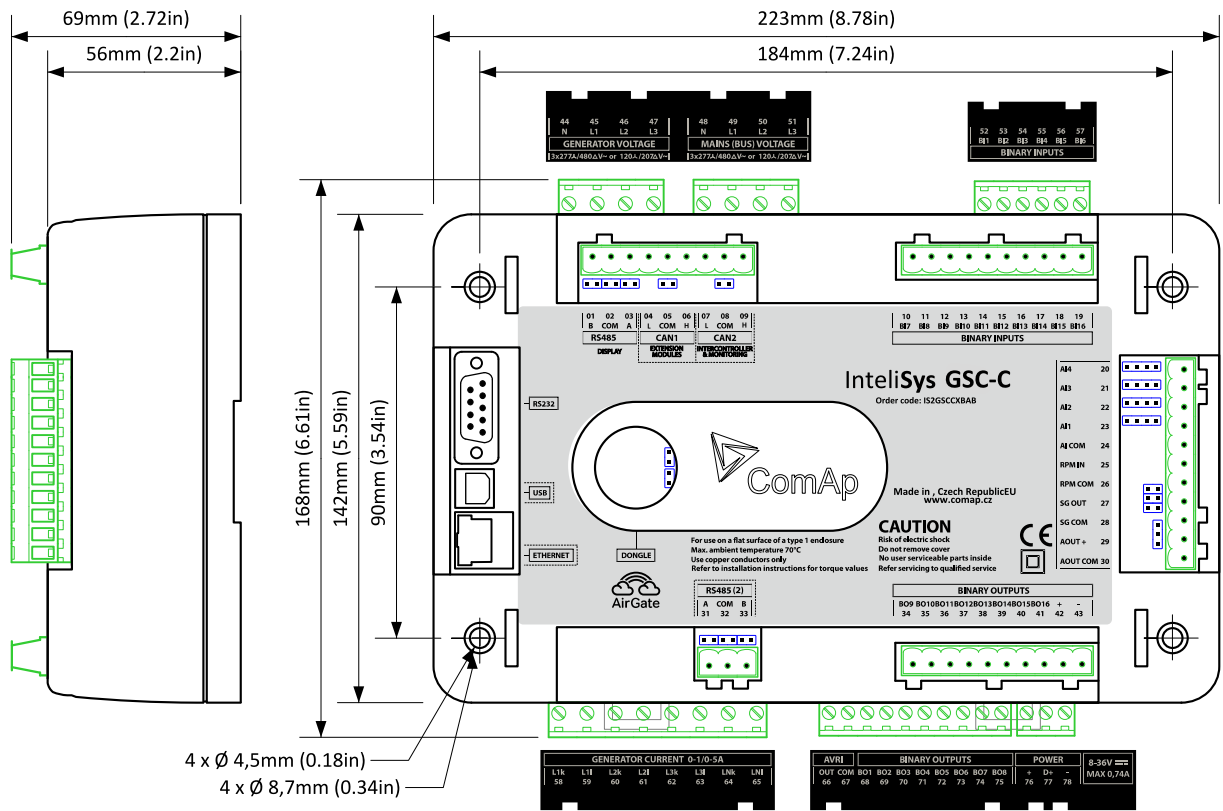

Panel door mounting (InteliVision 5)

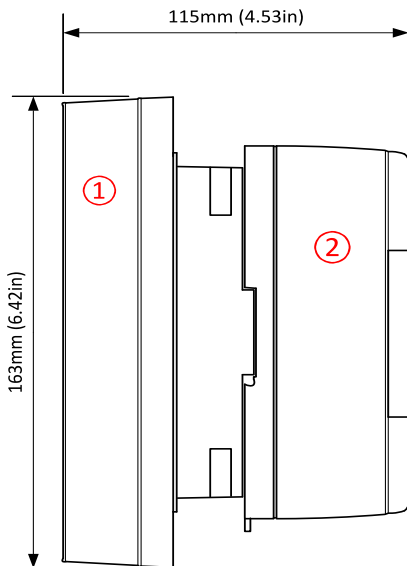

DIN rail mounting

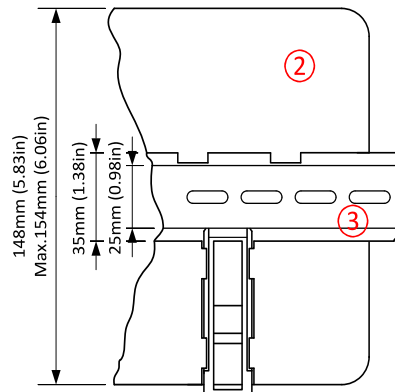

Panel door mounting (InteliVision 8)

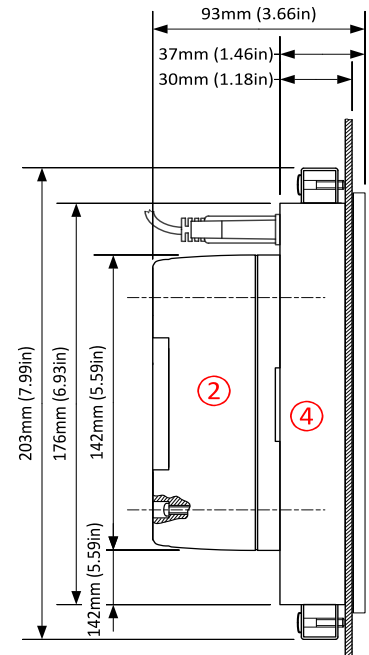

- ① IntelliVision 5
- ② IntelliSys GSC-C
- ③ DIN rail
- ④ IntelliVision 8

Available extension modules

Product	Description	Order code
Inteli IO8/8	8 Binary inputs, 8 Binary outputs and 2 Analog outputs in a small unit (HW switchable to IO16/0)	I-IO8/8
Inteli IO8/8	HW switchable to IO16/0 - 16 Binary inputs packed in a small unit	I-IO8/8
Inteli AIN8	8 Analog inputs (R, I, V) and 1 pulse/frequency input in a small unit	I-AIN8
Inteli AIN8TC	8 Thermocouple Analog inputs in a small unit	I-AIN8TC
Inteli AIO9/1	9 Analog inputs (4x DC, 4x thermocouples, 1x R) in a small unit	I-AIO9/1
IS-AIN8	8 Analog inputs packed in a rugged metal unit	IS-AIN8
IGS-PTM	8 Binary inputs, 8 Binary outputs, 4 Analog inputs and 1 Analog output in a unit	IGS-PTM
IGL-RA15	15 Binary LED output (3 colors) packed in a rugged metal unit	IGL-RA15
I-AOUT8	8 Analog outputs packed in a rugged metal unit	I-AOUT8
InternetBridge-NT	Multiple Internet connections (PC and Modbus) to all controllers on CAN2 or RS485	IB-NT
I-LB+	Direct connection (PC) to all controllers on CAN2 or RS485	I-LB+

Related products

Product	Description	Order code
InteliVision 5	Color 5.6" display for monitoring and control	INTELIVISION 5
InteliVision 8	Color 8" display for advanced monitoring, control & trending, USB capable	INTELIVISION 8
InteliVision 12Touch	Color 12" touch display for advanced monitoring, control & trending, USB capable	RD1IV12TBZH
InteliVision 18Touch	Color 18" touchscreen display designed for complete monitoring and control of multiple controllers or cogeneration installation.	RD31840PBIE

Functions and protections

Description	ANSI code	Description	ANSI code	Description	ANSI code	Description	ANSI code
Synchronism check	25	Excitation loss	40	Earth fault current IDMT	51N+64	AC reclosing	79
Undervoltage	27	Current unbalance	46	Power factor	55	Overfrequency	81H
Overload	32	Voltage asymmetry and phase sequence	47	Overvoltage	59	Underfrequency	81L
Reverse power	32R	Generator overcurrent	50	Gas (fuel) level	71	ROCOF	81R
Undercurrent	37	Earth fault current	50N+64	Vector shift	78		

Certificates and standards

<p>This product is CE compliant.</p> <ul style="list-style-type: none"> ▶ EN 60068-2-6 ed.2:2008 ▶ EN 60068-2-27 ed.2:2010 ▶ EN 60068-2-30:2005 25/55°C, RH 95%, 48hours ▶ EN 61010-1:2003 	<p>This product is compliant to:</p> <ul style="list-style-type: none"> ▶ European Requirements for Generators ▶ VDE-AR-N-4105:2018, VDE-AR-N-4110:2018 ▶ G99 ▶ IEEE 1547-2018 	
--	--	---